

HC Series

Conical Rounders



- Different models enabling dough rounding from 100 to 1000 grams between the rounding cone and adjustable or fixed rounding tracks
- Ideal and smooth rounding through long rounding tracks
- Aluminium rounding tracks
- Channels with on/off switch blowing warm air to prevent dough sticking
- Heavy duty long lasting gearbox drive
- Easily adjustable stainless steel flour duster
- Synchronization with automatic dough processing lines
- Stainless steel side panels

OPTIONAL

- Teflon-coated rounding tracks
- Teflon-coated rounding cone
- Narrow or wide rounding tracks depending on the product weight



SARMASIK
MAKINA SANAYII VE TICARET A.Ş.



Adjustable Rounding Track System

HC 4100 A

Technical Drawings

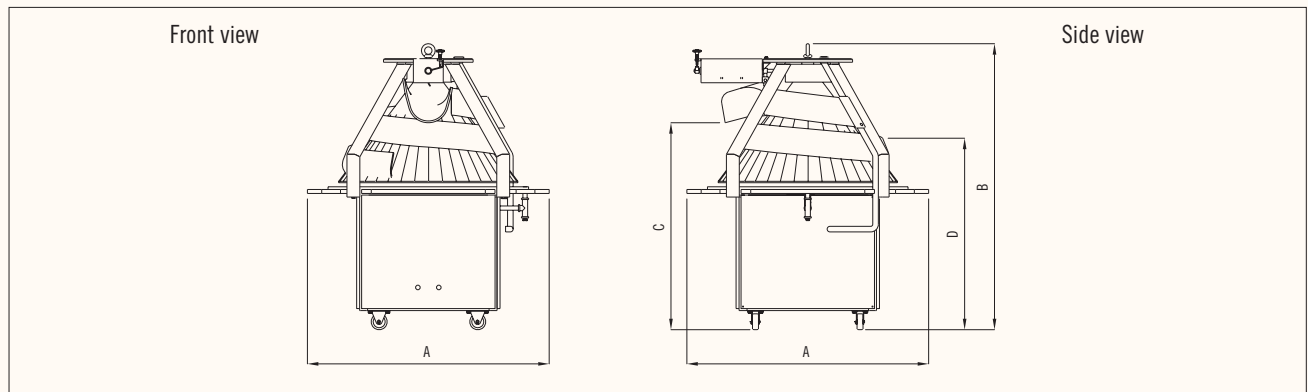

Technical Specifications

Model	Width-Length (A)	Height (B)	Dough Discharge Height (C)	Dough Infeed Height (D)	Weight Range	Power Requirement	Total Power	Heating Power	Weight
	cm	cm	cm	cm			g	kW	
HC 4100	122	145	90	88	100-1000	220-380V 50 Hz	1.1	1.00	340
HC 4100 A	127	163							400

Subject to alteration without prior notice.